

STRAUB-METAL-GRIP GT Ø 60.3 - 139.7 mm

Components / Materials	W1	W2	W4	W5
Casing		AISI 304	AISI 304	
Bolts		AISI 4135	A4 - 80	
Bars		AISI 12 L 14, galvanised	AISI 304	
Anchoring rings		AISI 301	AISI 301	

Sealing sleeve
EPDM Temp.: -20°C up to +70°C
 Medium: all qualities of water, waste water, air, solids and chemical products

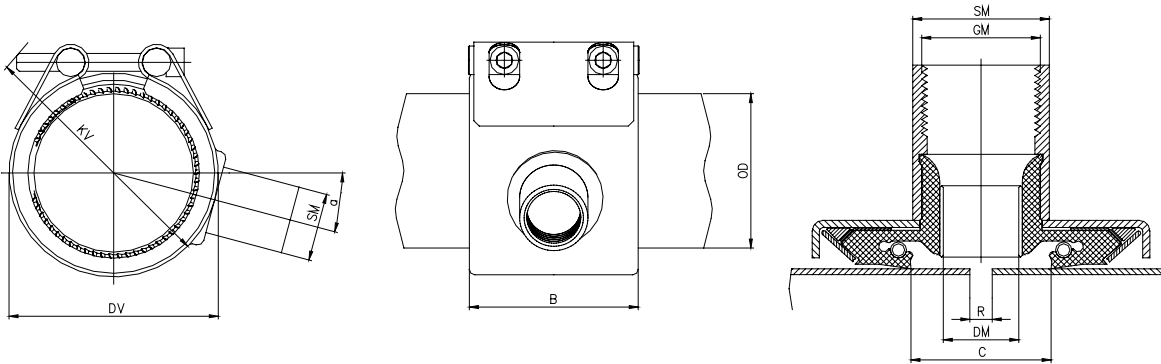

OD [mm]	Clamping range [mm]	PS [bar]	B [mm]	C [mm]	DV [mm]	KV [mm]	SM [mm]	GM [Zoll]	DM [mm]	R without strip insert [mm]	α [°]	Torque rate [Nm]
60.3	59.7 - 60.9	37.0	77	32	82	110	32	3/4	15	5 - 10	40	25
76.1	75.3 - 76.9	56.0	94	39	100	130	38	1	21	5 - 10	33	35
88.9	88.0 - 89.8	41.0	94	39	117	145	38	1	21	5 - 10	15	35
114.3	113.2 - 115.4	34.0	94	39	139	165	38	1	21	5 - 10	0	35
139.7	138.3 - 141.1	32.0	109	43	168	200	38	1	21	5 - 10	0	60

Remarks:

- Follow fitting / disassembly instructions
- PS = Working pressure considering the application loads
 Test pressure = PS x 1.5 (for example industry, water supply etc.)
- The pressure values are valid on radial rigid carbon steel pipes under static loads
- For minimum wall-thickness of pipe, see technical manual

For IPS sizes in bold see technical manual for actual OD

Typing errors may occur. Technical details are subject to change