

Components / Materials	W1	W2	W4	W5
Casing		AISI 316 L	AISI 316 L	AISI 316 L or similar
Bolts		AISI 4135	A4 - 80	A4 - 80
Bars		AISI 12L14, galvanised	AISI 304 / 316 L	AISI 316 L or similar
Anchoring rings		AISI A106, galvanised	AISI 304	AISI 301 / 304
Strip insert (option)		AISI 316 L or similar / PVDF	AISI 316 L or similar / PVDF	AISI 316 L or similar / PVDF
Sealing sleeve EPDM	Temp.: -20°C up to +100°C Medium: all qualities of water, waste water, air, solids and chemical products			
Sealing sleeve NBR	Temp.: -20°C up to +80°C Medium: water, gas, oil, fuel and other hydrocarbons			

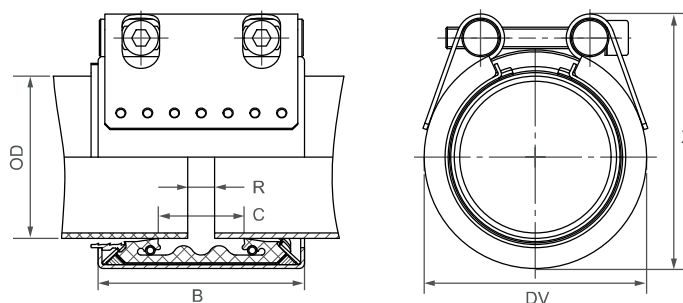

OD [mm]	Clamping range [mm]		PN [bar]	B [mm]	C [mm]	DV [mm]	X [mm]	R without strip insert [mm]	R with strip insert [mm]	Torque rate [Nm]	Allen head [mm]	Thread M...
	Plastic	Metal										
40.0/38.0	39.0 - 40.5	37.5 - 39.0	16.0	61	19	60	73	5	5 - 10	15	6	8
40.0/42.4	39.0 - 40.5	42.0 - 43.5	16.0	61	20	63	76	5	5 - 10	15	6	8
50.0/48.3	49.0 - 50.5	47.8 - 49.0	16.0	61	26	70	83	5	5 - 10	15	6	8
63.0/60.3	62.0 - 64.0	59.7 - 61.0	16.0	76	32	85	98	5 - 10	5 - 25	20	6	8
75.0/76.1	74.0 - 76.0	75.0 - 77.5	16.0	94	39	100	117	5 - 10	5 - 25	30	8	10
90.0/88.9	89.0 - 91.0	87.0 - 90.0	16.0	94	39	118	123	5 - 10	5 - 25	30	8	10
110.0/108.0	109.0 - 111.0	106.5 - 110.5	16.0	94	39	135	151	5 - 10	5 - 25	30	8	10
110.0/114.3	109.0 - 111.0	112.0 - 116.0	16.0	97	45	139	157	5 - 10	5 - 25	30	8	10
114.3/114.3	113.0 - 115.0	112.0 - 116.0	16.0	94	39	140	157	5 - 10	5 - 25	30	8	10
140.0/139.7	139.0 - 142.0	137.5 - 141.0	16.0	109	43	168	191	5 - 15	5 - 30	60	10	12
160.0/159.0	159.0 - 162.0	157.0 - 160.5	16.0/10.0 ¹	109	43	188	210	5 - 15	5 - 30	60	10	12
160.0/168.3 ¹	159.0 - 162.0	166.6 - 170.0	16.0	110	54	192	222	5 - 10	5 - 30	20	10	12
200.0/206.0	198.0 - 202.0	204.0 - 208.0	16.0	141	80	227	246	5 - 15	5 - 35	60	10	12
225.0/219.1	223.0 - 227.0	216.9 - 221.3	10.0	141	80	252	271	5 - 15	5 - 35	60	10	12
225.0/229.0	223.0 - 227.0	227.0 - 231.0	10.0	141	80	252	271	5 - 15	5 - 35	60	10	12
250.0/256.0	248.0 - 252.0	253.5 - 258.5	10.0	141	80	277	296	5 - 15	5 - 35	60	10	12
315.0/323.9	313.0 - 317.0	320.5 - 327.0	10.0	141	80	342	365	5 - 15	5 - 35	120	14	16
355.0/355.6	353.0 - 357.0	352.0 - 359.0	6.0	141	80	382	405	5 - 15	5 - 35	150	14	16

Remarks:

- Follow fitting instructions
- PN = working pressure considering the application loads
Test pressure = PN x 1.5 (for example industry, water supply etc.)
- For the installation of pipes of pipes made of HDPE and PP, STRAUB stiffening rings are required (see page 29)
- Strip inserts are optional accessories (see page 87)
- Additional sealing sleeves and temperature ranges on request

¹ 160.0/159.0 mm: version in W2 ⇒ PN 16 bar
version in W4 ⇒ PN 10 bar
160.0/168.3 mm: only available in W5